

Chromalox®

Installation, Operation

and

MAINTENANCE

SERVICE REFERENCE

DIVISION 4	SECTION CAF-12 CCAS-12
SALES REFERENCE (Supersedes PF493)	PF493-1
161-506171-001	
DATE	JULY, 2002

Architectural Convection Heaters Type CAF-12 and CCAS-12



CAF-12

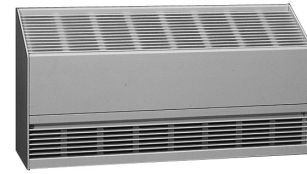

CCAS-12

TABLE 1 — Specifications

Model	Model	Volts	Phase	Watts	Amps	BTUH	Dimensions (In.)			Weight (Lbs.)
							Height	Length	Depth	
CAF-12F211	CCAS-12F211	208	1	1125	5.4	3,838	12	24.3	5.75	19
CAF-12F211	CCAS-12F211	208	3	1125	3.1	3,838	12	24.3	5.75	19
CAF-12F211	CCAS-12F211	240	1	1125	4.7	3,838	12	24.3	5.75	19
CAF-12F211	CCAS-12F211	277	1	1125	4.1	3,838	12	24.3	5.75	19
CAF-12F215	CCAS-12F215	208	1	1500	7.2	5,118	12	24.3	5.75	19
CAF-12F215	CCAS-12F215	208	3	1500	4.2	5,118	12	24.3	5.75	19
CAF-12F215	CCAS-12F215	240	1	1500	6.3	5,118	12	24.3	5.75	19
CAF-12F215	CCAS-12F215	277	1	1500	5.4	5,118	12	24.3	5.75	19
CAF-12F215	CCAS-12F215	480	3	1500	1.8	5,118	12	24.3	5.75	19
CAF-12F316	CCAS-12F316	208	1	1687	8.1	5,756	12	36.3	5.75	24
CAF-12F316	CCAS-12F316	208	3	1687	4.7	5,756	12	36.3	5.75	24
CAF-12F316	CCAS-12F316	240	1	1687	7	5,756	12	36.3	5.75	24
CAF-12F316	CCAS-12F316	277	1	1687	6.1	5,756	12	36.3	5.75	24
CAF-12F316	CCAS-12F316	480	3	1687	2	5,756	12	36.3	5.75	24
CAF-12F422	CCAS-12F422	208	1	2250	10.8	7,677	12	48.3	5.75	29
CAF-12F422	CCAS-12F422	208	3	2250	6.3	7,677	12	48.3	5.75	29
CAF-12F422	CCAS-12F422	240	1	2250	9.3	7,677	12	48.3	5.75	29
CAF-12F422	CCAS-12F422	277	1	2250	8.1	7,677	12	48.3	5.75	29
CAF-12F422	CCAS-12F422	480	3	2250	2.7	7,677	12	48.3	5.75	29
CAF-12F430	CCAS-12F430	208	1	3000	14.4	10,236	12	48.3	5.75	29
CAF-12F430	CCAS-12F430	208	3	3000	8.3	10,236	12	48.3	5.75	29
CAF-12F430	CCAS-12F430	240	1	3000	12.5	10,236	12	48.3	5.75	29
CAF-12F430	CCAS-12F430	277	1	3000	10.8	10,236	12	48.3	5.75	29
CAF-12F430	CCAS-12F430	480	3	3000	3.6	10,236	12	48.3	5.75	29
CAF-12F633	CCAS-12F633	208	1	3375	16.2	11,515	12	72.3	5.75	39
CAF-12F633	CCAS-12F633	208	3	3375	9.4	11,515	12	72.3	5.75	39
CAF-12F633	CCAS-12F633	240	1	3375	14.1	11,515	12	72.3	5.75	39
CAF-12F633	CCAS-12F633	277	1	3375	12.2	11,515	12	72.3	5.75	39
CAF-12F633	CCAS-12F633	480	3	3375	4.1	11,515	12	72.3	5.75	39
CAF-12F645	CCAS-12F645	208	1	4500	21.6	15,354	12	72.3	5.75	39
CAF-12F645	CCAS-12F645	208	3	4500	12.5	15,354	12	72.3	5.75	39
CAF-12F645	CCAS-12F645	240	1	4500	18.8	15,354	12	72.3	5.75	39
CAF-12F645	CCAS-12F645	277	1	4500	16.2	15,354	12	72.3	5.75	39
CAF-12F645	CCAS-12F645	480	3	4500	5.4	15,354	12	72.3	5.75	39
CAF-12F845	CCAS-12F845	208	1	4500	21.6	15,354	12	96.3	5.75	49
CAF-12F845	CCAS-12F845	208	3	4500	12.5	15,354	12	96.3	5.75	49
CAF-12F845	CCAS-12F845	240	1	4500	18.8	15,354	12	96.3	5.75	49
CAF-12F845	CCAS-12F845	277	1	4500	16.2	15,354	12	96.3	5.75	49
CAF-12F845	CCAS-12F845	480	3	4500	5.4	15,354	12	96.3	5.75	49
CAF-12F860	CCAS-12F860	208	1	6000	28.8	20,472	12	96.3	5.75	49
CAF-12F860	CCAS-12F860	208	3	6000	16.7	20,472	12	96.3	5.75	49
CAF-12F860	CCAS-12F860	240	1	6000	25	20,472	12	96.3	5.75	49
CAF-12F860	CCAS-12F860	277	1	6000	21.7	20,472	12	96.3	5.75	49
CAF-12F860	CCAS-12F860	480	3	6000	7.2	20,472	12	96.3	5.75	49

MODEL NUMBER DESCRIPTION

CAF-12 or CCAS-12	B	2	15	21	01	A9	Refer to Wiring Diagram
						Code Control Options (Factory Installed) 00 = No Control Options A9 = Built-in DP tamperproof hydraulic thermostat 208 - 277V A3 = Built-in 3P tamperproof hydraulic thermostat for 3P voltages 208 - 480V A4 = Built-in 24V low voltage relay for 1P voltages 208 - 277V A5 = Built-in 24V low voltage relay and transformer for 1P voltages 208 - 277V A6 = Built-in 24V contactor for 3P voltages 208 - 480V A7 = Built-in 24V contactor and transformer for 3P voltages 208 - 480V A8 = Built-in disconnect switch, rated 277V@20A B9 = Built-in DP tamperproof thermostat and disconnect B3 = Built-in 3P tamperproof thermostat and disconnect	
						Code Finish Painted Anodized 68 = Almond 07 = Bronze 02 = White 10 = Clear	
						Code Voltage/Phase 21 = 208/1 23 = 208/3 31 = 240/1 41 = 277/1 73 = 480/3	
						Code Wattage (See Table)	
						Code Length 2 = 2 ft. 3 = 3 ft. 4 = 4 ft. 6 = 6 ft. 8 = 8 ft.	
						Code Inlet Location F = Front B = Bottom	
Type							

GENERAL

This document explains the correct procedure for the installation and safe operation of all models of Draft Barrier and Pedestal Mounted Heaters.

Draft Barrier Heating Systems are designed to be installed in accordance with the National Electrical Code and with local codes by a qualified person.

General Information —

Draft Barriers and Pedestal Mounted Heaters are intended for wall, sill or floor mounting.

The heaters are designed so that they may be used as an individual cabinet convactor, in a wall-to-wall configuration or as an end-to-end continuous perimeter room heating system.

Draft Barrier heating systems are supported by a wide selection of controls and accessories designed to solve any heating requirement.

Before You Unpack —

1. Make certain that the number of cartons received agrees with the Bill of Lading, Packing List and original order. Also check that the correct style (Model) and color have been shipped.
2. Every heater is carefully inspected and shipped with a clear Bill of Lading.
Obvious external and/or concealed damage must be reported to the carrier for remedy.

WARNING: — Hazard of Fire

1. **DO NOT INSTALL HEATERS AGAINST ANY HIGHLY COMBUSTIBLE SURFACES SUCH AS LOW DENSITY CELLULOSE FIBRE.**
2. **DO NOT LOCATE HEATER BELOW ELECTRICAL CONVENIENCE RECEPTACLES.**
3. **DO NOT STORE OR USE GASOLINE OR FLAMMABLE LIQUIDS IN THE VICINITY OF THE HEATERS.**

WARNING: Hazard of Fire. The normal operating temperatures of cabinet convectors are relatively high and proper operation requires free circulation of room air through the heating element. Bottom

air inlet heaters must be mounted with minimum of 3" from finished floor.

WARNING: Hazard of Fire. Keep electrical cords, drapes, rugs and other furnishings away from the heater.

WARNING: Hazard of Fire. Furniture must be placed no closer than four inches from the heater (see Figure 1).

WARNING: Hazard of Fire. Drapes must clear the top of heater by at least twelve inches; or, if floor length drapes are used, they must clear the finished floor by three inches and the minimum clearance from the back fold to the front cover should be at least four inches (see Figure 1).

WARNING: Hazard of Fire. When the floor is to be finished in carpet, allow clearance under the heaters and corners for carpet installation. Bottom air inlet heaters are to be mounted a minimum of 3" from the finished floor.

WARNING: Hazard of Fire. Rugs may be placed up to a heater provided that they are not of a thickness that would block the air-intake. Bottom air inlet heaters are to be mounted a minimum of 3" from the finished floor.

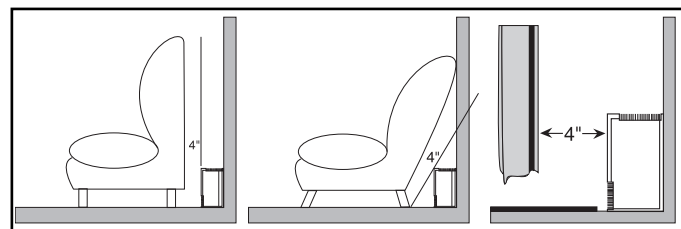

Figure 1: Furniture & Drapes

WIRING

1. Wire all heaters and controls in accordance with the appropriate wiring diagram provided below.
2. Run a ground jumper from the ground screw in one terminal box to the ground screw in the adjacent terminal box. (See Figure 4.)
3. Do a final and complete check of all wiring then replace the terminal box covers being careful not to pinch any wires.
4. The front panel may now be installed.
5. Place the front panel over the flange of the bottom panel. Hook the top back edge of the front panel over the top panel, and secure with screws.

Table 2: Terminal Box Volumes (Cubic Inches)

Heater Style	Left Hand Box 4" Wide	Right Hand Box 5" Wide
CAF-12, CCAS-12	146.25	182.75

WARNING: TO PREVENT THE RISK OF FIRE, DO NOT OPERATE THE HEATER WITHOUT THE FRONT PANEL IN PLACE.

WIRING DIAGRAMS

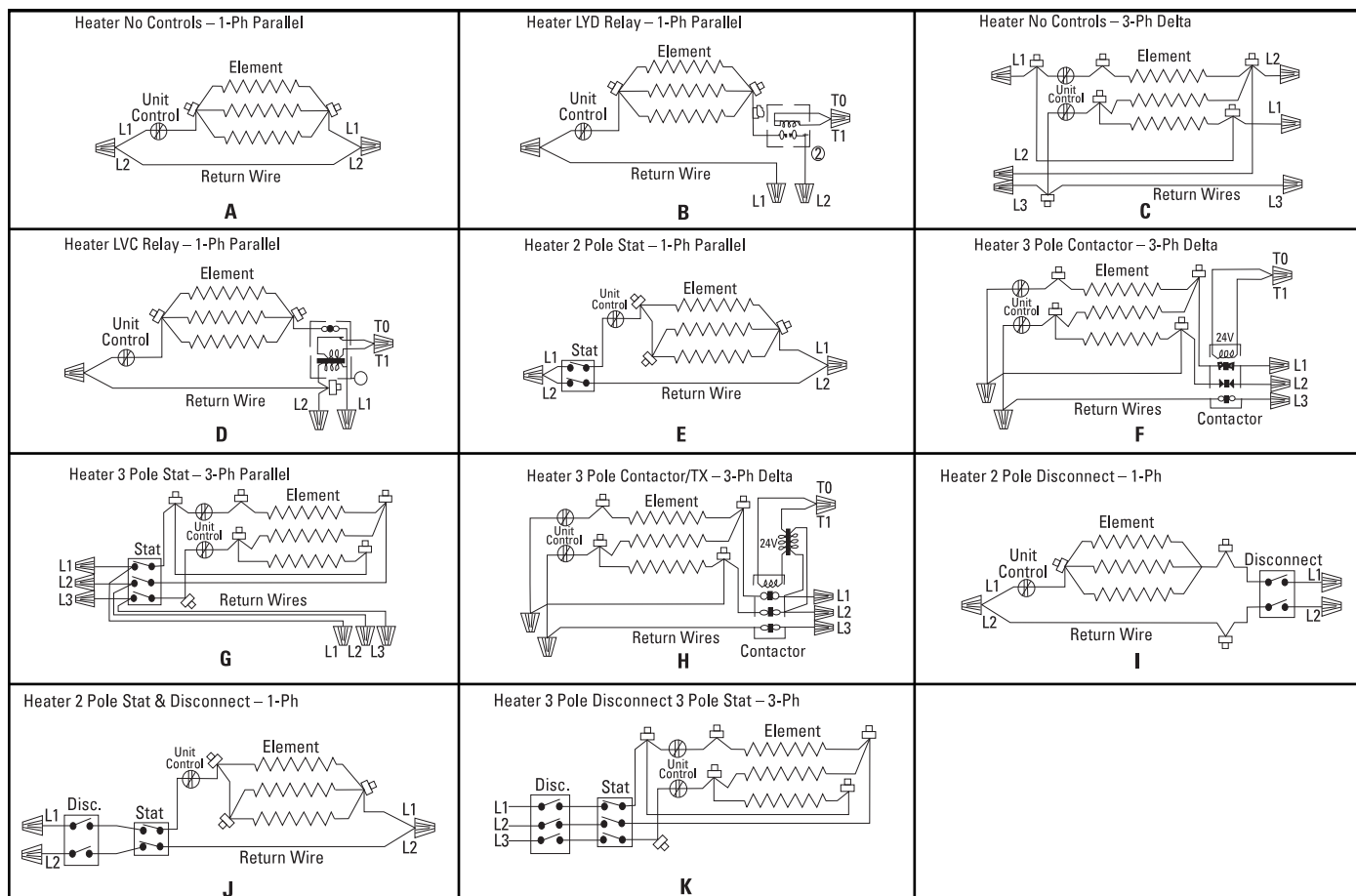

Limited Warranty:

Please refer to the Chromalox limited warranty applicable to this product at <http://www.chromalox.com/customer-service/policies/termsforsale.aspx>.

Chromalox[®]
PRECISION HEAT AND CONTROL

2150 N. RULON WHITE BLVD., OGDEN, UT 84404
Phone: 1-800-368-2493 www.chromalox.com